

## OPERATING INSTRUCTIONS AND PARTS LIST

for

# *Continental*



## **GASOLINE ENGINE**

**FOR DAVID BRADLEY GARDEN TRACTOR  
MODEL NUMBER 127.300**

The above number is the Model Number of your Continental Gasoline Engine. It will be found on a plate attached to the upper cylinder baffle. Always mention the Model and Serial Numbers of your engine when communicating with us or when ordering repair parts.

### **HOW TO ORDER PARTS**

All parts listed herein may be ordered through any Sears Roebuck and Co. retail or mail order store. In ordering parts by mail from the mail order store which serves the territory in which you live, Selling Prices will be furnished on request or parts will be shipped at prevailing prices and you will be billed accordingly.

**WHEN ORDERING REPAIR PARTS, ALWAYS GIVE THE FOLLOWING INFORMATION:**

1. The Part Number in this List.
2. The Part Name in this List.
3. The Model, Specification and Serial Numbers of your engine.

This list is valuable. It will assure your being able to obtain proper parts service at all times. We suggest you keep it with other valuable papers.

## **SEARS, ROEBUCK AND COMPANY**

# TABLE OF CONTENTS

	Page Number
Illustrations of Power Unit . . . . .	3
Technical Data. . . . .	4
Safety Precautions . . . . .	4
Engine Oiling System . . . . .	4
Engine Oil Recommendations . . . . .	5
Starting Engine . . . . .	5
Stopping Engine . . . . .	5
Daily Care . . . . .	5
Weekly Care . . . . .	6
Storage. . . . .	6
Trouble Shooting . . . . .	6-7
Carburetor Adjustment . . . . .	8
Mechanical Governor . . . . .	11
Removing Air Cleaner. . . . .	11
Carburetor Service . . . . .	9
Power Unit Base . . . . .	11
Piston . . . . .	11
Crankshaft . . . . .	11
Sticking Valves . . . . .	11
Valve Grinding. . . . .	11
Magneto . . . . .	16
Adjusting Breaker Point Gap . . . . .	17
Spark Plug . . . . .	11
Parts List. . . . .	12-15
External Breaker Point, Condenser and Governor System . . . . .	16-18
Carburetor Parts List. . . . .	19

# CONTINENTAL MODEL 127.300

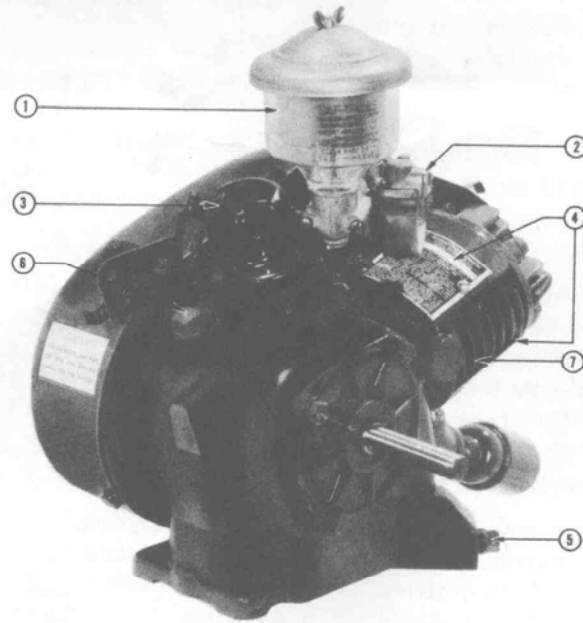

**Figure 1 - Drive End View of Power Unit**

- |                         |                   |
|-------------------------|-------------------|
| 1. Oil Bath Air Cleaner | 5. Oil Drain Plug |
| 2. Carburetor           | 6. Oil Gauge Rod  |
| 3. Mechanical Governor  | 7. Cooling Fins   |
| 4. Baffles              |                   |

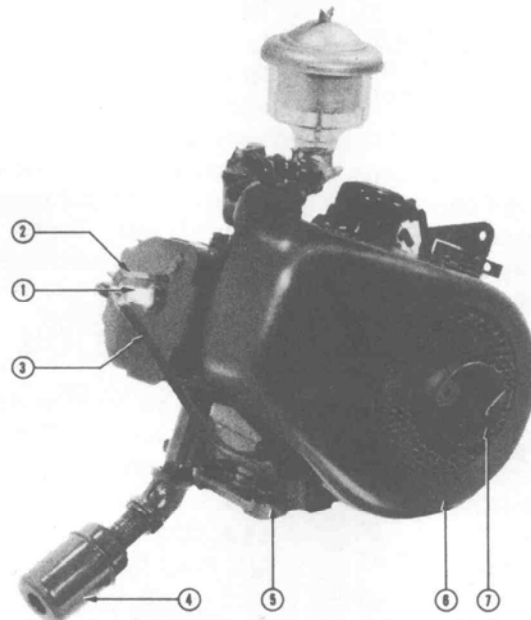

**Figure 2 - Rope Starter End View of Power Unit**

- |                         |                   |                        |
|-------------------------|-------------------|------------------------|
| 1. Spark Plug           | 4. Muffler        | 7. Rope Starter Pulley |
| 2. Ignition Cut Off     | 5. Engine Base    |                        |
| 3. Cylinder Head Baffle | 6. Blower Housing |                        |

# GENERAL INFORMATION

## FOREWORD

This instruction book is intended for use by operators as a guide and reference in using to the best advantage and servicing of the model number 127.300 Gasoline Engines which are backed by 50 years experience in the designing, manufacture and servicing of internal combustion engines.

All parts, as well as the complete unit, are carefully inspected and tested before leaving the factory and are guaranteed to be in first class condition. How well and how long these units will continue to give satisfactory performance depends largely on the attention and maintenance they receive by the operator.

The amount of attention required is small but important. If treated with reasonable care to which any high grade equipment is entitled, this engine will give long hours of dependable, trouble-free service.

The scope of this manual is necessarily limited but the intent is to give all essential information to the normal operation of this unit with several illustrations to clarify the text.

The Power Units are all purpose units designed to meet the needs of any tool or power equipment that requires up to 2 1/2 horse power. The engine is a single cylinder, air cooled type, operating on the four (4) cycle principle.

The carburetor is a centerbowl, float type unit with an adjustable idle and high speed jet. A Mechanical Governor, Air Cleaner, a dust proof and moisture proof flywheel magneto, blower housing, muffler, 4 quart fuel tank, fuel filter with shut-off valve and rope type starter are included as standard equipment.

## TECHNICAL DATA

Bore . . . . .	2-1/4"
Stroke . . . . .	2"
Cubic Inch Displacement . . . . .	7.95
Governed Speed in RPM . . . . .	3260
Max. Horse Power (Net) Model 127.300 . . . . .	2.5
Compression Ratio . . . . .	6.23 to 1
Rotation (Viewing the Driving End). . . . .	Counter-Clockwise
OIL CAPACITY IN PINTS . . . . .	1
Ignition. . . . .	Flywheel Magneto

Ignition Contact Point Setting . . . . .	.020"
Valve Clearance (Cold) . . . . .	.014"

## SAFETY PRECAUTIONS

Do not fill the fuel tank while the Power Unit is hot. Gasoline spilled on a hot engine will explode and might injure the operator.

**IF OPERATING THE POWER UNIT IN A CLOSED ROOM, PIPE THE EXHAUST GASES OUTSIDE AND SEE THAT THERE IS PLENTY OF VENTILATION. AN ENGINE WILL QUICKLY USE UP THE OXYGEN IN A ROOM, AND THE EXHAUST GASES CONTAIN CARBON MONOXIDE WHICH IS COLORLESS, ODORLESS AND DEADLY POISON.**

In performing service operations which require the cleaning of dirty parts in gasoline, be sure to use UNLEADED or so-called WHITE gasoline only. Leaded gasoline is poisonous and highly injurious.

## ENGINE OILING SYSTEM

The method of oil distribution within these engines is of the dependable splash system type. The oil reservoir is within the engine base from which the oil is automatically metered into a dipper trough where the desired oil level is maintained by gravity flow. The trough is aligned with a dipper attached to the large end of the connecting rod. With the engine in operation, even at lower speeds, the rapidly rotating crankshaft causes the lubricating oil to be splashed throughout the engine crankcase and cylinder, thereby providing an ample supply of oil to all interior working parts of the engine.

## ENGINE OIL RESERVOIR LEVEL

The oil level should be checked every 5 operating hours. The oil should be drained and refilled with new, fresh oil after every 25 hours of operation. On the engine base there is a plug (Item 5, Fig. 1) for draining the oil. Oil may be added by removing the oil gauge rod (Item 6, Fig. 1) and filling until the oil reaches the full mark on the rod. When replenishing, or refilling the oil through opening provided, care should be exercised against over-filling. Over oiling and spark plug fouling can result from this. The refill capacity is ONE PINT.

## ENGINE OIL RECOMMENDATIONS

Good lubricating oils properly used is your cheapest insurance in engine operating satisfaction. Oil body is popularly expressed by the SAE Grading System whereby different grades are specified for the several seasons of the year. A study of the factors involved in the several types of services to which these Engines are put, has developed a recommendation of three grades of oil for the three seasons, as set forth in the following chart.

Where Temperatures Are		
Above 32° F.	32° F: to 0° F.	Below 0° F.
SAE 30	SAE 20W	SAE 10W

The use of American Petroleum Institute classification of Premium grade oils of high viscosity index (minimum 95) is recommended.

## STARTING

Before starting your new Power Unit inspect it thoroughly. See that all accessories are properly installed and take the following precautions in the order outlined.

- 1- Check equipment to see if you have received everything you ordered.
- 2- Fill the crankcase (making certain that all containers are clean when used) with one (1) pint of a good grade of oil. (See above chart for correct grades of oil.) When oil is poured into the oil filler opening (Item 6, Fig. 1) be sure that the proper level is obtained in the crankcase. The correct amount of oil is very important in the operation of the engine. Check every 5 hours.
- 3- Fill reservoir of the Oil Bath Air Cleaner with recommended grade of oil No. 50 for summer use No. 20 for winter.
- 4- Fill fuel tank with regular gasoline purchased from a reputable dealer and open shut off valve.
- 5- CAUTION: Keep gasoline cap clean and see that vent hole is not plugged.
- 6- Open carburetor throttle about 1/3 and close the choke. Wind rope on rope starter pulley (Item 7, Fig. 2) clockwise and give a quick steady pull.
- 7- After engine starts, adjust choke so engine operates smoothly and set throttle at a normal speed until engine is warmed-up. The

amount of choke used will depend on the weather. The colder it is the more choke will be required and for a longer period of time. Be sure choke is off before applying load. All engines are tested at the factory. If engine fails to start, follow Trouble Shooting instructions, page 6 and 7.

- 8- After the first 5 hours of operations, drain and refill with new oil. Thereafter check oil after every 5 hours of operation so that the proper level is continuously maintained.
- 9- The idle speed of the governor is set at 1500-1800 RPM at the factory under no load. Because the maximum speed can be varied, it is recommended that same be held between 2000 and 3600 RPM under load if long and uninterrupted service is desired.

## STOPPING

By pressing the ignition Cut-Out spring (Item 2, Fig. 2) on to the spark plug (Item 1, Fig. 2), the engine can be stopped instantly.

After letting the engine cool it is important to refill the tank with gasoline to prevent gum forming as result of oxidation with adjacent air. This gum will form on the inside eventually getting into the carburetor and engine causing the various moving parts to stick.

## DAILY CARE

Check engine over periodically to see that there are no loose bolts or nuts, etc. This spot check will insure more satisfactory operation and longer uninterrupted service.

**DO NOT ALLOW DIRT TO ACCUMULATE ON THE ENGINE AND UNDER THE CRANKCASE BAFFLES (ITEM 3, FIG. 2). A CLEAN ENGINE ENCOURAGES MORE CAREFUL OPERATION AND INSURES GREATER SAFETY.**

The baffles (Item 4, Fig. 1) can be loosened to facilitate cleaning by releasing spring between the parts.

Add the grade of oil most suitable for the temperature expected before starting up each day making sure the proper level is obtained.

## WEEKLY CARE

Oil should be changed at least after every 25 hours of operation.

Air cleaner should be inspected at least once a week or oftener depending on daily use.

Oil should be added to the cleaner only when serviced.

## STORAGE

If your engine is to be laid up for a month or more, be sure to drain the fuel system. This will prevent the formation of gum.

At least once a week spin the engine over with the rope starter several times. This provides fresh oil to all friction surfaces and not only keeps the piston, rings, cylinder wall, bearings, etc., from becoming dry and corroding but from scuffing up when starting again.

## TROUBLE SHOOTING

TROUBLE	CAUSE	REMEDY
Fails to Start	Lack of fuel	Open shut-off valve wide Fill Tank Take high speed adjustment out (Item 1, Fig. 3) There should be a good stream of fuel. Reset high speed jet, turn open.
	Choke doesn't close	Reset control lever.
	Cylinder flooded with gasoline	Open choke and throttle wide and crank until it fires; then close throttle about 2/3 and adjust choke to keep engine running.
	Dirt	Disassemble carburetor and blow out all passages including fuel line and sediment bowl and even the fuel tank if it appears necessary.
	No Spark	Hold spark plug wire about 1/8" from plug while cranking. If no spark occurs, remove plug and check gap .025" is correct. Check high tension wire -- if shorting, replace. If spark occurs, remove plug and see if spark occurs at gap. If it does not spark, replace with new plug. Magneto contact points burned. File, clean and adjust. Setting .020".
Starts but Stops	No Spark	Condenser shorted -- replace with new condenser. Coil shorted -- replace with new coil. Weak magnets -- recharge magnets.
	Lack of fuel	Set choke valve more carefully. Open shut-off valve wide.

## TROUBLE SHOOTING (Continued)

TROUBLE	CAUSE	REMEDY
Poor Idling	Dirt	Remove idle adjustment (Item 2, Fig. 3) and clean.
	Air Leak	Check by squirting light oil over both manifold flanges. Tighten bolts at offending points. If leak persists, replace gaskets.
	Cracked spark plug	Replace spark plugs.
	Wrong plug gap	Adjust gap to .025" (approximately the thickness of a dime).
Poor Compression	Loose cylinder head bolts	Tighten (IT IS GOOD PRACTICE TO CHECK TIGHTNESS OF CYLINDER HEAD BOLTS AFTER 1ST & 5TH HOUR OF OPERATION AND REGULARLY THEREAFTER).
	Damaged head gasket	Replace head gasket.
	Valves leak	Grind valves.
	Improperly seated valves	Check valve stems for carbon, causing them to hold open. Remove carbon if found.
	Broken valve spring	Replace.
	Stuck, worn or broken piston rings	Loosen rings and replace if necessary.
Smoky Exhaust	Excessive oil consumption	Stuck, worn or broken piston rings.
	Excessive fuel consumption	Check high speed carburetor adjustment. Make sure choke stays open while running.
Overheating	Restricted flow of air over cylinder	Remove baffle and check -- remove any obstruction.
	Dirt on and between fins	Clean with a stiff brush.
	Too lean fuel mixture	Check carburetor adjustment. Check for air leaks.
	Running too slow to furnish sufficient air for cooling	Speed up at low load until cooled sufficiently.
	Lack of sufficient oil	Check oil level and add whatever is necessary. Check dipper to see that it is not broken or bent.

# GENERAL OPERATING INSTRUCTIONS

choke and start engine in usual manner and run until thoroughly warm.

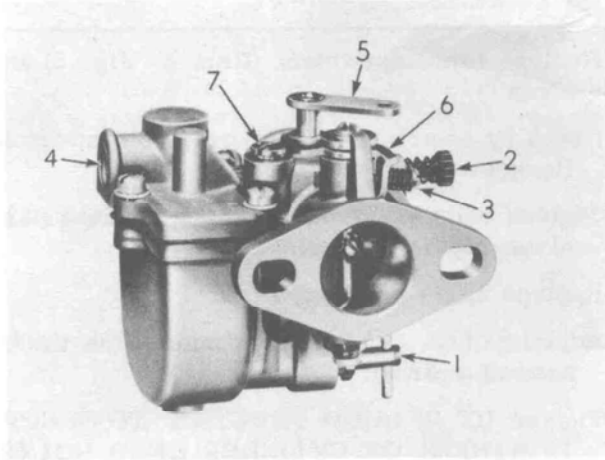

**Figure 3**

- (1) - Main (Power Range Adjustment Screw)
- (2) - Idle Adjustment Screw
- (3) - Idle Speed Regulating Screw
- (4) - Fuel Inlet Connection
- (5) - Choke Lever
- (6) - Throttle Stop Lever
- (7) - Idle Tube

## CARBURETOR ADJUSTMENT INSTRUCTIONS

Before starting engine-check for proper fuel supply in tank. Open Fuel Line Shut Off Valve and be certain air valve on Fuel Tank cap is open.

Separate manual carburetor adjustments are provided. Main Adjustment Screw (1) controlling power range mixture and Idle Adjustment Screw (2) governing idle mixture at closed throttle and Idle Speed Regulating Screw (3) controlling required idling speed.

**INITIAL ADJUSTMENT:** Completely close Idle Adjustment Screw (2) by turning in (clockwise) until seated (without forcing) then turn back in opposite direction three-fourths (3/4ths) of a turn. Proceed in like manner with Main Adjustment Screw (1) except open one (1) full turn after first being closed. Now

**POWER RANGE ADJUSTMENT:** With engine running at a constant speed of approximately one-half (1/2) open throttle position, slowly turn Main Adjustment Screw (1) inward (clockwise) until motor begins to lose speed, then slowly turn back in opposite direction (usually 1/8 to 1/4th of a turn) until maximum speed and power is obtained which is then final adjustment setting for required power performance.

**IDLE RANGE ADJUSTMENT;** This adjustment should only be made **AFTER** the above mentioned power range adjustment has been completed. Allow engine to idle at no load governed speed. Adjust Idle Adjustment Screw (2), by turning to right (inward) for leaner mixture - left (outward) for richer mixture, until a relatively smooth or constant governed idle operation is obtained. Adjust Idle Speed Regulating Screw (3) to give desired idling speed. This setting will then give proper performance throughout the range.

**FINAL ADJUSTMENT:** Alternately open and close throttle a few times for adjustment test. If acceleration hesitancy or stalling at idle speed occurs, entire adjustment procedure, outlined above, should be repeated bearing in mind that either a rich or lean adjustment causes flatness. If this condition still exists completely check and service the unit as outlined below. Preceding instructions cover Cold Motor start only. Warm Motor only requires opening of throttle and one or two vigorous pulls on starter rope without further carburetor adjustment. Regardless of altitude or climatic conditions a proper carburetor adjustment can be made by following the above rules—which eliminates jet changes.

**FLOAT LEVEL:** To set correctly, remove carburetor Float Bowl Cover and float mechanism assembly. Then remove Float Bowl Cover Gasket and with complete assembly in inverted, or upside down, position and Float Lever Tang resting on seated Inlet Needle a

measurement of one and thirteen thirty-seconds ( $1\text{-}13/32$ nds) inches should be maintained from free end flat rim, or edge, of cover (minus gasket) to then top edge of float. Measurement can be checked with a standard straight rule or depth gauge. If necessary to raise or lower float lever setting, remove Float Lever Pin and Float, then carefully and evenly bend Float Lever Tang (which contacts Inlet Needle) up or down as required, to obtain above mentioned correct measurement. (DO NOT CHANGE FLOAT LEVEL SETTING FROM MANUFACTURER'S SPECIFICATIONS).

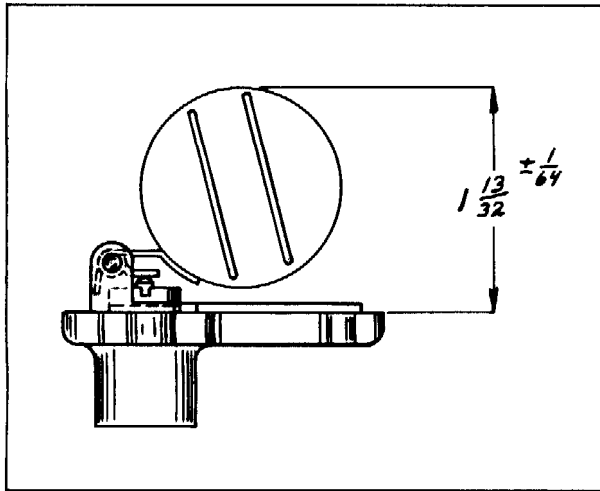

Figure 4

## CARBURETOR MAINTENANCE SERVICE HINTS

**DISASSEMBLING:** To correctly service carburetor remove following parts in order indicated, no special tools being required:

1. Float Bowl Cover Assembly.
2. Float and Inlet Needle and Seat from Cover.
3. Main Adjustment Screw Assembly.
4. Idle Adjustment Screw and Spring.
5. Idle Tube.
6. Main Nozzle and Gasket (If stuck invert body casting and jar or pry out.)
7. Throttle and Choke Shaft need not be removed unless carburetor has been ex-

cessively used and examination discloses undue wear of throttle shaft and its bearings, permitting leakage of air at that point and rendering improper idle performance, thereby requiring installation of new Throttle Shaft and Shutter.

**CAUTION:** If, or when, necessary to remove Choke Shaft, be careful not to lose Choke Shaft Friction Pin and Spring located inside casting channel behind lower end of shaft, by holding thumb over channel opening while withdrawing Shaft. When reinstalling Shaft, first Friction Spring then Pin must be reinserted into original position and held therein with heavy kitchen match stick, or steel drift pin, until Choke Shaft is carefully slid down and by this point.

**CLEANING AND INSPECTING:** Submerge carburetor body casting in clean gasoline or other recommended cleaning solution and thoroughly wash out all possible grit or sediment therein. Then carefully blow compressed air thru all internal fuel and air bleed channels. If necessary remove welch plug and check Idle Mixture Discharge Ports (M) to be certain they are not wholly or partially plugged, then **TIGHTLY** install new welch plug. Wash and blow out Main Nozzle (S) and Idle Tube (I). Carefully inspect Main Adjustment Screw (R), Idle Adjustment Screw (L) and Inlet Needle, Seat and Gasket (D). If the pointed surface has become grooved, especially Inlet Needle which will wear more rapidly and possibly prevent correct fuel level maintenance, completely replace. Always replace Gaskets and Main Adjustment Screw Packing. (A complete Repair Parts Kit (including Gasket and Packing Set) is available for each model carburetor and recommended when servicing an excessively used or worn unit to guarantee accurate work and performance).

**REASSEMBLING:** To reassemble reverse the above disassembly instructions when installing parts indicated. Be sure to carefully and tightly install Main Nozzle (S), Idle Tube (H) and Inlet Seat (D). Also see that Float moves freely and is set at specified level.

After carburetor has been reinstalled on engine, thoroughly flush out fuel line before connecting thereto. Finally, follow Adjustment Instructions as outlined herein.

**CAUTION:** Do not blow compressed air into carburetor bore or channels when not disassembled as damage to float will result.

## HOW IT OPERATES

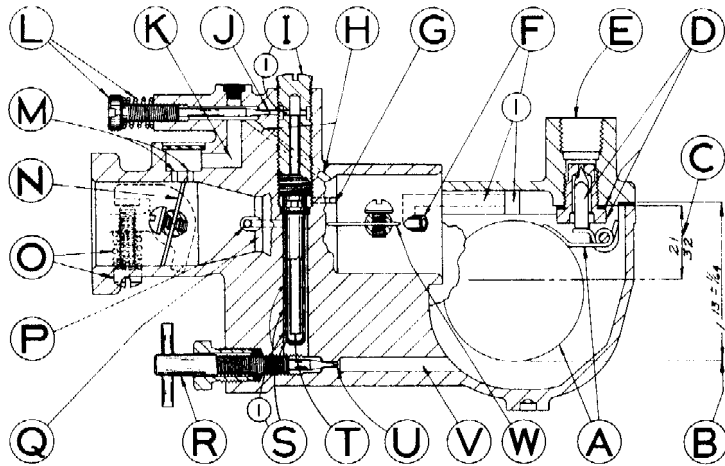

Figure 5

- A Float
- B Float Level Setting
- C Fuel Level
- \*D Inlet Needle, Seat and Gasket
- E Fuel Inlet Connection
- F&F-1 Internal Air Vent Tube and Channel
- G Main Nozzle Air Bleed Channel
- H Internal Idle Air Bleed Channel
- \*I Idle Tube
- I-1 Idle Tube Fuel Outlet Holes
- \*J Idle Fuel Adjustment Orifice
- K Idle Mixture Supply Channel
- L Idle Adjustment Screw and Spring
- \*M Idle Mixture Discharge Ports
- N Throttle Shutter
- O Idle Speed Regulating Screw and Spring
- \*P Main Fuel Outlet Jet
- Q Venturi
- R Main Adjustment Screw
- S Main Nozzle
- \*S-1 Nozzle Fuel Inlet Sump
- \*T Idle Tube Fuel Inlet Orifice
- \*U Main Fuel Adjustment Orifice
- V Main Fuel Supply Channel
- W Choke Shutter

(\* ) Indicates channels or orifices of which inside dimensions are variable in each model of the "MT" Series carburetors according to calibration requirements of engine adapted to.

**INLET CONNECTION:** Fuel enters carburetor at Inlet Connection (E) flowing down past Inlet Needle and Seat (D) into the Fuel Bowl until proper fuel level is reached.

**INLET NEEDLE, SEAT AND GASKET:** A constant fuel level is maintained in Fuel Bowl and all lower channels of the carburetor by Inlet Needle, Seat and Gasket (I) and Float (A).

**FUEL LEVEL:** In reaching its level, fuel flows from Fuel Bowl through Main Fuel Supply Channel (V) past Main Fuel Adjustment Orifice (U) then into lower part of Main Nozzle Sump (S-1) and Idle Tube stem through its Restriction Orifice (T).

**IDLE AND LOW SPEED:** High manifold vacuum, or suction, at closed or slightly opened Throttle Shutter (N) draws this fuel up through Idle Tube (I) and out its Idle Tube Outlet Holes (I-1) past Idle Adjustment Orifice (J) where it then mixes with air from Internal Idle Air Bleed Channel (H). This fuel-air mixture is drawn through Idle Mixture Supply Channel (K) and Idle Mixture Discharge Ports (M) into and mixing with additional air stream passing Throttle Shutter (N) before entering

engine intake port. Idle Adjustment Screw (L) regulates amount of fuel requirements only. Idle air bleed supply is fixed and predetermined by size of Internal Idle Air Bleed Channel (H).

**HIGH SPEED AND FUEL POWER:** When engine is pulling a load, Throttle Shutter (N) has been further opened (manual or governor controlled) thereby reducing suction and minimizing fuel discharge at Ports (M) and increasing air flow to a high velocity through Venturi (Q) creating vacuum or suction, at Main Fuel Discharge Jet (P). This suction draws fuel, supplied by Fuel Bowl, through Channel (V) past Main Fuel Adjustment Orifice (U) then up around Main Nozzle (S) and out the Main Fuel Discharge Jet (P) where it is completely atomized with high velocity air stream entering engine intake Port. As engine speed or load increases, air is automatically bled into the Main Nozzle Air Bleed Holes (S-1) from Internal Air Bleed Channel (G), rendering a proper proportion of fuel, in relation to adjustment, to be metered at that particular speed range.

## GOVERNOR AND CONTEXT IGNITION SYSTEM

This model engine is equipped with the latest development of an easily accessible mechanical governor with outside breaker points and condenser assembly. Service instructions follow plate 2, page 16.

### AIR CLEANER

The Oil Bath Air Cleaner (Item 1 Fig. 1) can be removed by unscrewing the wing nut on top. This permits the long bolt to drop out and the cleaner to come apart. The filtering element should be washed in clean gasoline, then dipped in lubricating oil that is used in the engine and allowed to drain for one hour. Wash out the oil reservoir likewise making sure the sides are cleaned of all dirt and sludge and when reassembling fill this reservoir up to the mark indicating the proper level with clean oil using No. 50 for summer operation and No. 20 for winter use. This will eliminate excessive ring wear. CAUTION: Fill cleaner with oil only when serviced. This service should be carried out on a regular schedule.

### ENGINE BASE

The engine base is secured to the crankcase by two bolts which it is necessary to remove from the internal parts can be checked.

After removing the base, flush both the base and the oil dip trough with clean gasoline to remove the sludge which may exist. Make sure that the oil level hole in the trough is open.

Before putting the base and crankcase back together, replace the gasket between these parts.

### PISTON

When the engine begins using an excessive amount of oil the FIRST service piston ring set can be obtained to take care of cylinder wear up to .010". When the bore is worn in the neighborhood of .010", the cylinder will have to be rebored .020" oversize and a new .020" oversize piston and piston rings installed. Then a SECOND service ring set can be obtained which will take care of another .010" wear.

### CRANKSHAFT

The ball bearing (power take-off end), is a press fit on the crankshaft. Unless this part needs replacing, do not attempt to remove it. The timing gear and spacer are an integral part of the crankshaft and cannot be removed.

If a new crankshaft is ordered, it will include the part which is pressed on. If the crankshaft pin journal is scored or worn more than .003" it would be ground either

.010 or .020" undersize and the necessary associated parts ordered.

### VALVES

Sticking valves, which can be identified by popping back thru the carburetor or a leaking sound in the exhaust manifold, are due to a collection of varnish on the valve stems near the head and the coking of certain fractions of the fuel or lube oil in this area.

To overcome a sticking inlet valve, feed about a cupful of Casite, or similar solvent through the carburetor - slowly at first and finally at a rate sufficient to stall the engine. After allowing the engine to stand for about half an hour in order to give the solvent a chance to work, repeat the process until the inlet valve is free.

In the case of a sticking exhaust valve which is more often due to lead deposits, the safest way is to remove the valve and burnish it.

If much running is done after valve sticking starts, it is wise to pull the cylinder head, clean the valves, grind-in the valves that need it, clean out the fuel tank and be more careful of the next fuel you buy.

To remove gum once formed in a fuel tank line and carburetor, a mixture of two parts of alcohol, one part benzol and one part acetone is an excellent solvent.

The necessity of grinding valves is usually detected by poor idle or lack of power due to loss of compression caused by the valve heads or seats warping and pitting and not forming a good seat. This necessitates grinding.

CAUTION: Avoid the use of old gasoline.

### SPARK PLUG

The Spark Plug which should be used in this engine is a 14 MM Champion J8 or its equivalent. At periodic intervals when the engine is being "Tuned Up", the Spark Plug should be inspected for cracked porcelain, fouling and point gap.

A plug that is operating properly will have a light tan color on the porcelain nose. Fouled plugs with the porcelain covered with carbon or lead compounds, indicate too rich a fuel-air mixture, late spark timing, poor valve seating, missing or high oil consumption due to broken or stuck rings and excessive ring wear.

Point gap setting should be .025" to give a good all around performance. This should be checked by a feeler or better still a spark plug gauge.

CAUTION: To re-set the gap, do not touch or strain the center electrode. Bend the side electrode only.

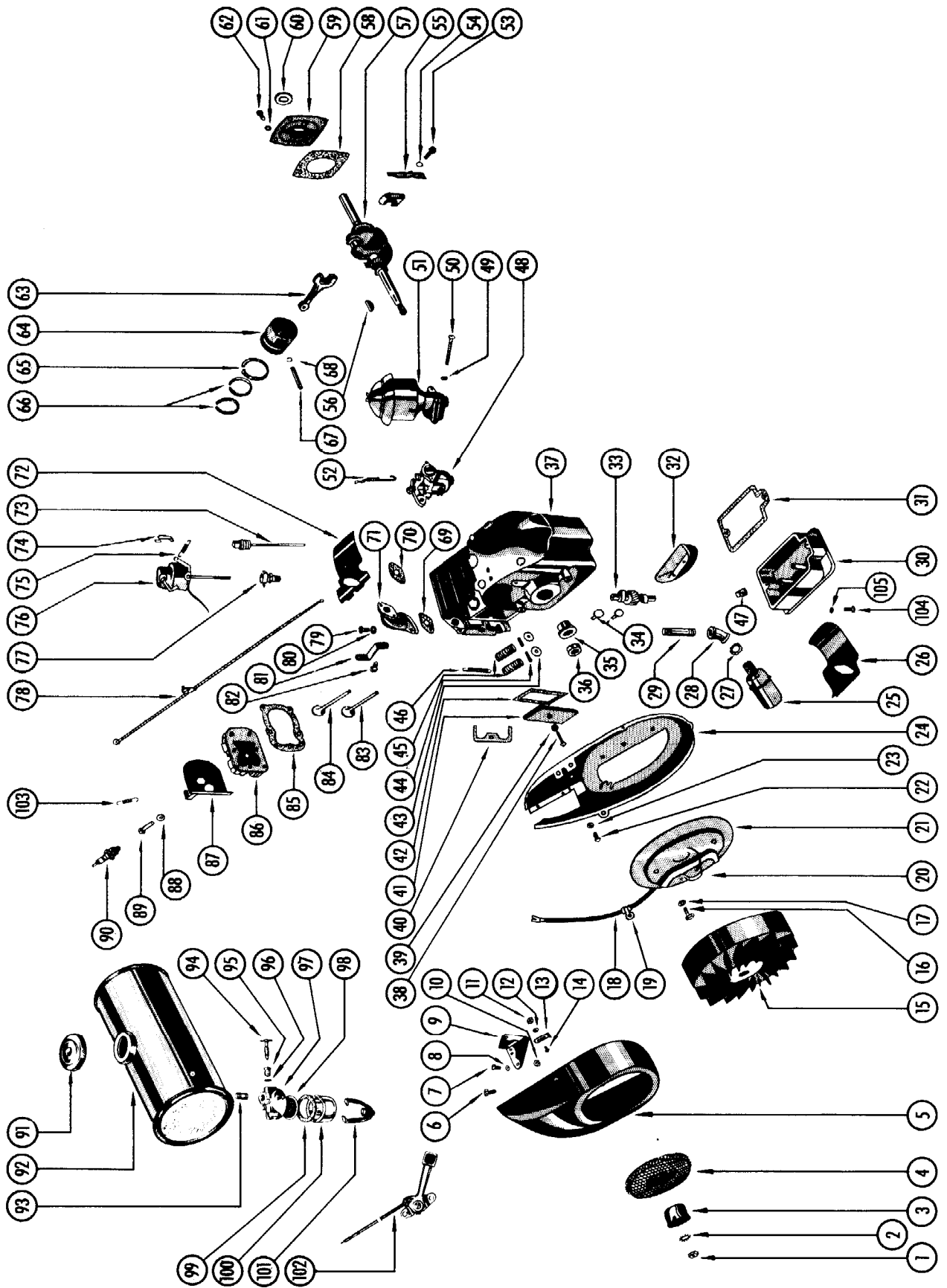

**PARTS LIST**  
for  
**DAVID BRADLEY GARDEN TRACTOR GASOLINE ENGINE - MODEL 127.300**

Item No.	Part No.	Description	Qty. Req'd.	Shipping Lbs.	Wt. Oz.
1	X-1890	Nut - Flywheel & Pulley to C'shaft . . . . .			1
2	GM-114756	Lockwasher - Flywheel & Pulley to C'shaft . . . . .			1
3	AA7C-314	Pulley - Rope Starter . . . . .			5
4	AA7K-305	Screen - Rotating . . . . .			2
5	AA7K-521	Shroud Assy. - Fan . . . . .		1	8
6	GM-113970	Bolt - Fan Shroud to Backplate . . . . .	3		1
7	GM-112873	Screw - Throttle Control Bracket to Shroud . . . . .	2		1
8	X-229	Lockwasher . . . . .	2		1
9	AA7S-351	Bracket - Control Cable Attachment . . . . .			2
10	GM-110633	Nut - Throttle Control Bracket to Shroud Screws . . . . .	2		1
11	GM-110633	Nut - Control Cable Stop Screw . . . . .			1
12	X-229	Lockwasher - Control Cable Stop Screw . . . . .			1
13	AA7SA-202	Stop - Control Cable . . . . .			1
14	GM-113903	Screw - Control Cable Stop to Bracket . . . . .			1
15	Y-6714	Rotor . . . . .		3	13
16	GM-113970	Screw - Stator Plate to Crankcase . . . . .	2		1
17	X-201	Lockwasher - Stator Plate to Crankcase Screw . . . . .	2		1
18	X-6840	Lead Wire Group . . . . .			1
19	AA7M-251	Clip - Lead Wire to Shroud . . . . .			1
20	X-7536	Coil Group . . . . .			3
21	X-7708	Stator Plate Repl. Assy. . . . .		1	1
22	GM-113970	Screw - Backplate to Crankcase . . . . .	3		1
23	X-201	Lockwasher - Backplate to Crankcase . . . . .	3		1
24	AA7K-4440	Shroud Backplate Assy. . . . .			1
25	AA7E-4001	Muffler Assy. . . . .			4
26	AA7K-445	Baffle - Cylinder Air (Lower) . . . . .			3
27	AA7A-204	Lockwasher - Muffler . . . . .			1
28	GM-119094	Elbow - Nipple to Muffler . . . . .			3
29	AA7B-234	Nipple - Muffler Extension . . . . .			2
30	AA7B-493	Base - Engine . . . . .		4	8
31	AA7B-302	Gasket - Engine Base . . . . .			1
32	AA7B-408	Trough - Oil . . . . .			3
33	AA7I-216	Camshaft . . . . .			6
34	AA7I-301	Tappet - Valve . . . . .	2		1
35	AA7G-238	Bearing - Crankshaft . . . . .			1
36	AA7M-227	Seal - Oil, Crankshaft . . . . .			1
37	AA7B-5320	Cylinder & Crankcase Assy. . . . .		13	4
	Includes	(1) AA7B-532 Cyl. & C'case (1) AA7G-229 Bearing (1) AA7A-215 Insert (1) AA7I-273 Gov. Drive Shaft Oil Seal			
38	GM-113962	Screw - Tappet Chamber Cover to Cyl. . . . .			1
39	X-202A	Washer - Tappet Chamber Cover to Cyl. Screw . . . . .			1
40	AA7K-446	Baffle - Backplate to Cyl. . . . .			1
41	AA7A-202	Cover - Tappet Chamber . . . . .			3
42	AA7A-203	Gasket - Tappet Chamber Cover . . . . .			1
43	AA7I-204	Seat - Valve Spring . . . . .	2		1
44	AA7I-205	Pin - Valve Spring Lock . . . . .	2		1
45	AA7I-203	Spring - Valve . . . . .	2		1
46	AA7K-206	Spring - Air Baffle Connecting . . . . .			1
47	GM-103867	Plug - Oil Drain . . . . .			1
48	AA7F-4830	Carburetor Assy. (Tillotson MT25A) See exploded view (plate 3, page 19) . . . . .			14
49	X-230	Lockwasher - Air Cleaner to Carb. Bolt . . . . .	2		1
50	GM-100721	Screw - Air Cleaner to Carburetor . . . . .	2		1

Item No.	Part No.	Description	Qty. Req'd.	Shipping Lbs.	Wt. Oz.
51	AA7F-2003	Air Cleaner Assy. - Oil Bath . . . . .			7
	Includes	(1) AA7F-339 Elbow	Up to Serial No. 451700		
	(Available as separate parts in service)	(1) AA7F-257 Body (Plastic)			
		(1) AA7F-2560 Filter Assy.			
		(1) AA7F-261 Cover			
	AA7F-4900	Air Cleaner Assy. - Oil Bath . . . . .			
	Includes	(1) AA7F-339 Elbow	Starting Serial No. 451701		
	(Available as separate parts in service)	(1) AA7FA-226 Body (Plastic)			
		(1) AA7FA-2210 Filter Case Assy.			
		(1) AA7FA-222 "O" Ring			
		(1) AA7F-4740 Bolt & Wing Nut Assy.			
52	AA7SA-207	Rod - Carburetor to Governor Cover . . . . .			1
53	AA7D-200	Bolt - Cap to Connecting Rod . . . . .			1
54	X-201	Lockwasher - Cap to Connecting Rod Bolt. . . . .	2		1
55	AA7D-300	Dipper - Oil . . . . .			1
56	X-503	Key - Flywheel to Crankshaft. . . . .			1
57	AA7C-433	Crankshaft (Incl. Gear & Spacer). . . . .		3	
Not Shown	X-13041	Bearing - Ball, Crankshaft . . . . .			4
58	AA7B-301	Gasket - Crankshaft Bearing Cap, 1/64". . . . .			1
	AA7B-309	Gasket - Crankshaft Bearing Cap, 1/32". . . . .			1
	AA7B-311	Shim - Crankshaft Bearing Cap, .004". . . . .			1
59	AA7B-331	Bearing Cap . . . . .			12
60	AA7M-205	Oil Seal . . . . .			1
61	X-202B	Washer - Lock, Crankshaft Brg. Cap Bolt. . . . .	4		1
62	X-3777	Bolt - Crankshaft Brg. Cap to Crankcase . . . . .	4		1
63	AA7D-4030	Rod and Cap Assy. - Connecting . . . . .			4
	AA7D-4030-.010	Rod and Cap Assy. - .010" Undersize . . . . .			4
	AA7D-4030-.020	Rod and Cap Assy. - .020" Undersize . . . . .			4
	AA7D-4030-.030	Rod and Cap Assy. - .030" Undersize . . . . .			4
64	AA7A-408	Piston . . . . .			5
	AA7A-408-.010	Piston - .010" Oversize. . . . .			5
	AA7A-408-.020	Piston - .020" Oversize. . . . .			5
	AA7A-408-.030	Piston - .030" Oversize. . . . .			5
65	AA7A-304	Piston Ring - Oil Control. . . . .			1
	AA7A-304-.010	Piston Ring - Oil Control, .010" Oversize. . . . .			1
	AA7A-304-.020	Piston Ring - Oil Control, .020" Oversize. . . . .			1
	AA7A-304-.030	Piston Ring - Oil Control, .030" Oversize. . . . .			1
66	AA7A-303	Piston Ring - Compression . . . . .			1
	AA7A-303-.010	Piston Ring - Compression, .010" Oversize . . . . .			1
	AA7A-303-.020	Piston Ring - Compression, .020" Oversize . . . . .			1
	AA7A-303-.030	Piston Ring - Compression, .030" Oversize . . . . .			1
Not Shown	AA7A-3070	Piston Ring Set . . . . .			2
	AA7A-3070-.010	Piston Ring Set, .010" Oversize . . . . .			2
	AA7A-3070-.020	Piston Ring Set, .020" Oversize . . . . .			2
	AA7A-3070-.030	Piston Ring Set, .030" Oversize . . . . .			2
Not Shown	AA7A-3080	Piston, Rings & Connecting Rod Assy. . . . .			10
	AA7A-3080-.010	Piston, Rings & Connecting Rod Assy., .010" Oversize . . . . .			10
	AA7A-3080-.020	Piston, Rings & Connecting Rod Assy., .020" Oversize . . . . .			10
	AA7A-3080-.030	Piston, Rings & Connecting Rod Assy., .030" Oversize . . . . .			10

Item No.	Part No.	Description	Qty. Req'd.	Shipping Wt. Lbs.	Oz.
67	AA7A-200	Pin - Piston . . . . .			1
	AA7A-200-.005	Pin - Piston, .005" Oversize . . . . .			1
	AA7A-200-.010	Pin - Piston, .010" Oversize . . . . .			1
68	AB13A-205	Ring - Piston Pin Retaining . . . . .	2		1
69	AA7F-205	Gasket - Manifold to Cylinder. . . . .			1
70	AA7F-205	Gasket - Carburetor to Manifold. . . . .			1
71	AA7F-444	Manifold. . . . .			5
72	AA7K-421	Baffle - Cylinder Air (Upper). . . . .			3
73	AA7B-3100	Oil Gauge Rod . . . . .			3
74	AA7T-272	Clip - Retainer . . . . .			1
75	AA7T-279	Spring - Governor . . . . .			1
76	AA7S-5010	Governor Assembly (See exploded view plate 2, page 16) . . . . .			12
77	AA7B-2440	Breather Assy. . . . .			1
78	AA7T-2830	Choke Control Assy. . . . .			3
79	GM-216914	Bolt - Manifold to Cylinder . . . . .	2		1
80	X-201	Washer, Lock, Manifold to Cylinder Bolt . . . . .	2		1
81	AA7P-249	Support, Choke Control Cable. . . . .			1
82	X-3943	Bolt - Carburetor & Support to Manifold . . . . .	2		1
83	AA7I-302	Valve - Exhaust . . . . .			2
84	AA7I-303	Valve - Intake . . . . .			2
85	AA7A-305	Gasket - Cylinder Head. . . . .			1
86	AA7A-507	Head - Cylinder. . . . .			14
87	AA7K-4370	Baffle - Cylinder Head with Ignition Cutoff . . . . .			4
88	X-14219	Washer - Cylinder Head Bolt . . . . .			1
89	GM-179820	Bolt - Cylinder Head . . . . .	7		1
90	SP202-J8	Spark Plug . . . . .			2
91	AA7F-214	Cap - Fuel Tank. . . . .			1
92	AA7F-4003	Tank Assy. - Fuel (4 qt.). . . . .		3	
93	GM-142868	Nipple - Tank to Strainer . . . . .			1
	AA7F-3002	Fuel Strainer Assy (Complete) . . . . .			5
	94 100-7	Valve - Fuel Shut Off } Serviced as complete assy.			1
	95 100-6	Packing - Nut } under Part No. 100-7			1
	96 100-9	Packing - Fuel Strainer Shut Off Valve. . . . .			1
	97 100-1	Cover - Fuel Strainer. . . . .			2
	98 100-11	Screen - Fuel Strainer . . . . .			1
	99 100-10	Gasket - Fuel Strainer Bowl to Cover . . . . .			1
	100 100-2	Bowl - Fuel Strainer. . . . .			1
	101 100-3	Clamping Assy. . . . .			1
102	AA7T-2770	Throttle Control Assy. . . . .			12
103	AA7K-306	Spring - Cyl. Head Baffle to Cyl. Head. . . . .			
104	GM-179847	Bolt - Engine Base to Crankcase . . . . .	2		
105	X-203	Lockwasher - Engine Base to Crankcase . . . . .	2		

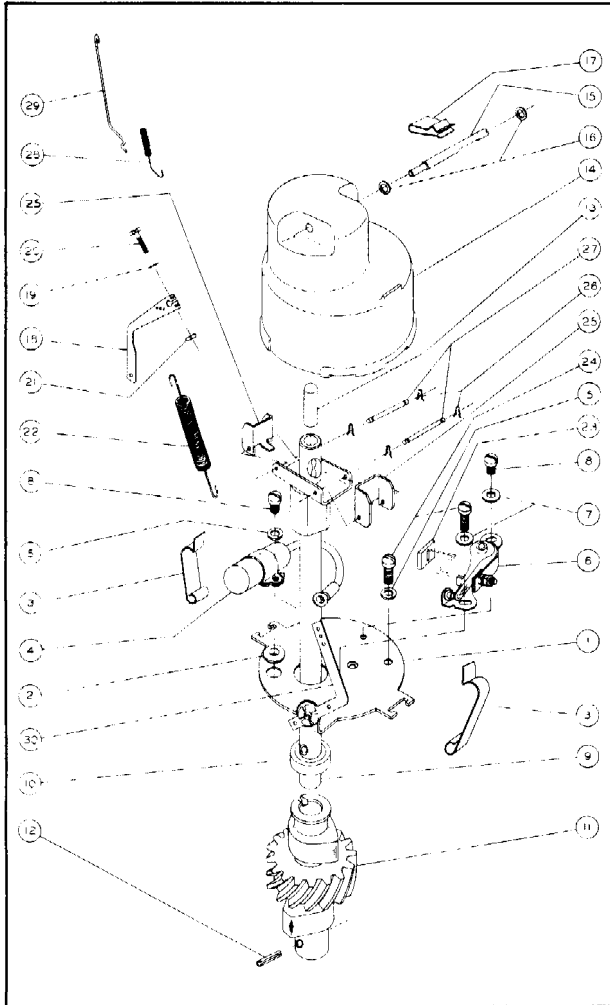

**PLATE 2**

Item No.	Part No.	Description
1	AA7S-4120	Base & Lever Assy.
2	AA7M-286	Grommet - Ignition Wire
3	AA7T-272	Clip - Retainer (2 Req'd)
4	AA7M-2980	Condenser Assembly
5	GM-118873	#10 Plain Light Lockwasher (2 Req'd)
6	AA7M-2990	Breaker Point Assembly
7	GM-446151	Plain Washer, 13/64 I.D. - 15/32 O.D. (2 Req'd)
8	GM-110485	#10-24 x 1/4 Fill. Hd. Screw (2 Req'd)
9	AA7S-3530	Shaft, Ignition Cam, Retainer and Flyweight
10	AA7T-273	Seal
11	AA7I-216	Camshaft Assembly
12	AAI-217	Pin Camshaft
13	AA7S-276	Plunger - Governor Actuating
14	AA7S-406	Housing - Governor
15	AA7T-267	Shaft - Governor
16	GM-446143	Washer - Plain 3/16 I.D. - 3/8 O.D. - 1/16 Thick (2 Req'd)
17	AA7T-268	Lever - Governor Actuating
18	AA7T-266	Lever - Governor
19	GM-446121	Plain Washer, 5/32 I.D. - 5/16 O.D.
20	AA7T-282	#6-32 x 5/8 Slotted Screw
21	GM-134532	#6-32 Sq. Nut
22	AA7T-279	Spring - Governor
23	AA7N-205	Pad Cam Wiper
24	GM-110488	#10-24 x 5/8 Fill. Hd. Screw
25	AA7T-269	Flyweight (2 Req'd)
26	AA7SA-204	Spring Retainer (4 Req'd)
27	AA7T-299	Pin - Flyweight (2 Req'd)
28	AA7T-292	Spring - Governor Rod
29	AA7SA-207	Rod - Governor to Carburetor
30	AA7T-271	Lever - Governor Control

## CONTEXT IGNITION AND GOVERNOR SYSTEM

(BEFORE MAKING ANY ADJUSTMENT OR REPAIRS TO THIS UNIT,  
DISCONNECT REMOTE CONTROLS FROM THROTTLE LEVER (30)(PLATE 2)

### A. Governor Linkage Adjustment:

An adjustment has been provided to compensate for normal wear of governor parts and connecting linkage. The adjustment to optimum governor action is made as follows:

1. Move throttle lever (30) to half throttle position.
2. Loosen lever arm screw (20) until the lever (18) will turn freely on shaft (15).
3. Hold the top carburetor shaft lever (not shown) in wide open position and secure

it in that position by the use of a rubber band or suitable clamp.

4. Engage a screwdriver in slot of shaft (15) and apply a light pressure in a clockwise direction. This forces lever (17) down on a plunger (13) which in turn pushes the flyweights into the upright position.
5. While holding the shaft in this position tighten the arm screw (20). The screw must be pulled down very tightly to avoid slippage at this point.
6. Remove rubber band or clamp from carburetor and check for free movement of governor linkage.

#### B. Breaker Point Adjustment (.020")

It is only necessary to remove the plastic cover to expose the breaker points for adjusting. This is accomplished as follows:

1. Disconnect and remove governor spring (22) noting which hole in lever (18) is being used.
2. Snap clips (3) from cover (14) and lift cover from plate (1). The Governor Rod (not shown) can then be disconnected from the bottom carburetor lever (not shown) by lifting the cover up and toward the cylinder head.
3. Use feeler gage and check breaker point setting. Correct setting is .020" when the flat on shaft (9) is directly opposite the fibre rubbing block on breaker assembly (6).
4. To change setting, loosen 2 screws (8) until the breaker assembly (6) can be moved about its pivot by tapping lightly with a screwdriver handle.
5. Check contacts for pitting. If the points are not excessively pitted, clean them with a suitable ignition type file. If badly scored, remove 2 screws (8) and washers (7) replace assembly (6) by disconnecting primary lead and condenser lead and install new assembly.
6. Move breaker assembly (6) until the .020" feeler gage just touches both sur-

faces of the contact points as the gage is drawn through the point opening.

7. Tighten 2 screws (8) and recheck the .020" point opening. Turn engine over several times to make sure that the points are closing when the fibre rubbing block drops into the flat of the shaft (9).
8. Check tightness of 2 screws (8).
9. Wipe off any excess oil that may have accumulated on base (1) and lubricate cam wiper felt (23) with 3 or 4 drops of SAE 30 lubricating oil and apply a drop of oil to each side of the governor flyweight pins (9). Do not over lubricate.
10. To re-assemble the cover (14), hook the governor rod into the lower carburetor lever (not shown) and carefully place the cover over the assembly. It will be noted that there are several notches in the bottom of the cover and these must register with the corresponding tabs of plate (1). Lightly twist the cover to right and left to make sure that the cover is seated on the plate. The lever (18) should be directed down. If not, remove cover and reassemble with lever (17) resting on plunger (13).
11. While applying a downward finger pressure on the top of the cover, snap the 2 clips (3) over the lugs on the cover. Re-check to make certain that the cover is properly located on plate (1).
12. Re-assemble the spring (22) into its original position (see 1 above). The short hook should be connected to the rod lever (18).
13. Check throttle control to see that the linkage is operating freely.
14. Re-adjust governor linkage if necessary (See "A" above).

#### C. To Check or Change the Condenser

1. Remove cover (14) from plate (1) following instructions of "B" above.

2. Condenser (4) is then dis-assembled by removing hold-down screw (8) and washer (7) and disconnecting wire from terminal of breaker assemble (6).

3. When re-assembling the condenser, make sure that it is in the same location as the one which was removed since the condenser will interfere with the cover or shaft is improperly installed.

D. Complete Dis-assembly and Assembly of Unit.

1. Remove engine base from engine.

2. Remove cover(14) following instructions of "B" above.

3. Remove plunger (13).

4. Using a 1/16 dia. drift, drive out roll-pin (12) (inside crankcase). (It is suggested that a 5/16 dia. rod or drill approximately "4" inches long be used to follow the shaft (9) when it is removed. This will keep the camshaft (11) in position until shaft is replaced.)

5. Remove shaft (9) by pulling it up through the camshaft (11) and seal (10).

6. Disconnect wires from binding post of breaker assembly (6).

7. Remove (2) screws (8) and washers (7) which hold the base to the crankcase (one of these screws also holds the breaker assembly (8) in position) and remove base plate assembly. The lead wire can be pulled through the grommet (2).

8. Clean all parts by washing in gasoline or fuel oil, check for excessive wear of moving parts and replace if required

9. To remove seal, insert screwdriver in shaft hole and pry out. Do not re-use this seal. Assemble new seal with seal lip toward engine crankcase. This is a press fit and an assembly tool must be used to avoid damage to the seal in assembly. A seal which has been deformed

cannot be used since the base assembly (1) uses the exposed outside diameter of the seal for a pilot. Lubricate a new seal lip with several drops of SAE 30 oil.

10. Bring primary wire through grommet (2) in base plate (1) and position base plate over locating seal (10).

11. Engage 2 screws (8) and washers (7). Tighten the screw which does not engage the breaker point assembly.

12. Assemble shaft (9) by pushing the shaft through the seal and camshaft. When pushing shaft into position, watch that the lower edge of the cam on the shaft does not damage the fibre block on the breaker assembly. Pre-align pin holes in shaft and camshaft by using a suitable wire and drive pin (12) into position.

13. Turn engine over several times to make sure that there are no binds or other interferences.

14. Assemble primary wire and condenser wire to binding post on breaker point assembly (6) and lay wire into position around breaker points as in the original assembly. Turn engine over to make sure flyweights are not rubbing the wire.

15. Assemble plunger (13) by dropping in place. This part should be a free fit in its position.

16. Adjust contact points as per instructions of section "B", Paragraphs 3, 4, 5, 6, 7 and 8.

17. Lubricate cam wiper felt (23) and governor flyweight pins using several drops of SAE 30 oil. Do not over lubricate.

18. Assemble cover and carburetor rod following instructions in section "B" above.

19. Adjust governor linkage following instructions in Section "A".

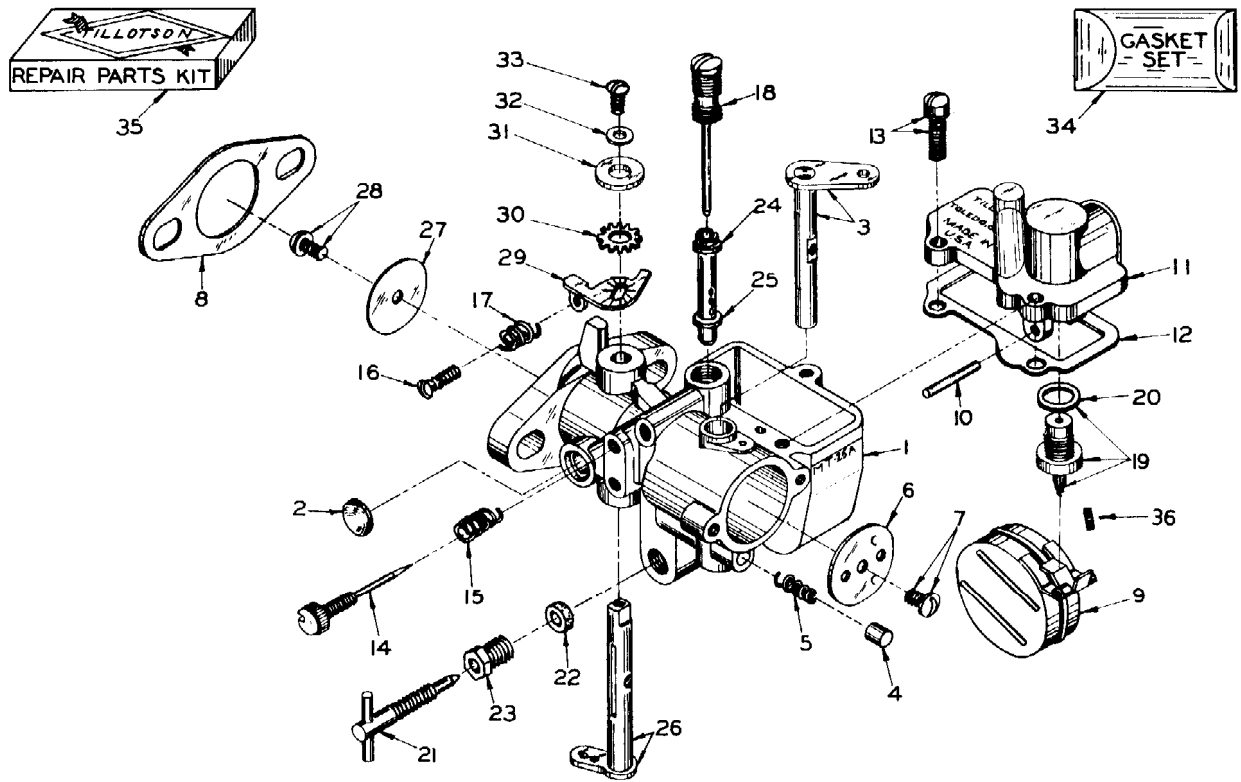

**PLATE 3 - CARBURETOR**

Ref. No.	No.	Req.	Part No.	Part Name	Ref. No.	No.	Req.	Part No.	Part Name
1	1		09643	Body . . . . .	20	1		02510	Inlet Seat Gasket . . . . .
2	1		*02531	Body Channel Welch Plug . . . . .	21	1		*07972	Main Adjustment Screw . . . . .
3	1		08800	Choke Shaft & Lever . . . . .	22	1		0705	Main Adjustment Screw Packing . . . . .
4	1		*05454	Choke Shaft Friction Plunger . . . . .	23	1		07282	Main Adjustment Screw Packing Nut . . . . .
5	1		*08805	Choke Shaft Friction Plunger Spring . . . . .	24	1		*09640	Main Nozzle . . . . .
6	1		05088	Choke Shutter . . . . .	25	1		06076	Main Nozzle Gasket . . . . .
7	1		08317	Choke Shutter Screw & Lockwasher . . . . .	26	1		09637	Throttle Shaft & Lever . . . . .
8	1		08880	Flange Gasket . . . . .	27	1		08646	Throttle Shutter . . . . .
9	1		08656	Float . . . . .	28	1		*08942	Throttle Shutter Screw & Lockwasher . . . . .
10	1		*08796	Float Lever Pin . . . . .	29	1		09067	Throttle Stop Lever . . . . .
11	1		08619	Float Bowl Cover . . . . .	30	1		*08988	Throttle Stop Lever Retainer Lockwasher . . . . .
12	1		08658	Float Bowl Cover Gasket . . . . .	31	1		*09641	Throttle Stop Lever Retainer Washer (Large) . . . . .
13	3		08315	Float Bowl Cover Screw & Lockwasher . . . . .	32	1		*03804	Throttle Stop Lever Retainer Washer (Small) . . . . .
14	1		*08765	Idle Adjustment Screw . . . . .	33	1		*06393	Throttle Stop Lever Retainer Screw . . . . .
15	1		*08793	Idle Adjustment Screw Spring . . . . .	34			*08827	GASKET & PACKING SET . . . . .
16	1		*09066	Idle Speed Regulating Screw . . . . .	35			09652	REPAIR PARTS KIT . . . . .
17	1		*09068	Idle Speed Regulating Screw Spring . . . . .	36			09119	Spring - Needle Valve . . . . .
18	1		*08875	Idle Tube . . . . .					
19	1		*09145	Needle, Seat, Gasket & Spring . . . . .					

(\* ) Indicates Contents of REPAIR PARTS KIT)